

STUBBY™

... by WeldTec®

REPLACEMENT PARTS

WTS-18 200 AMPS WATER COOLED

SEE GUIDE FOR ADDITIONAL TORCH FRONT END OPTIONS

CAUTION
Head must be tightened firmly before starting arc.

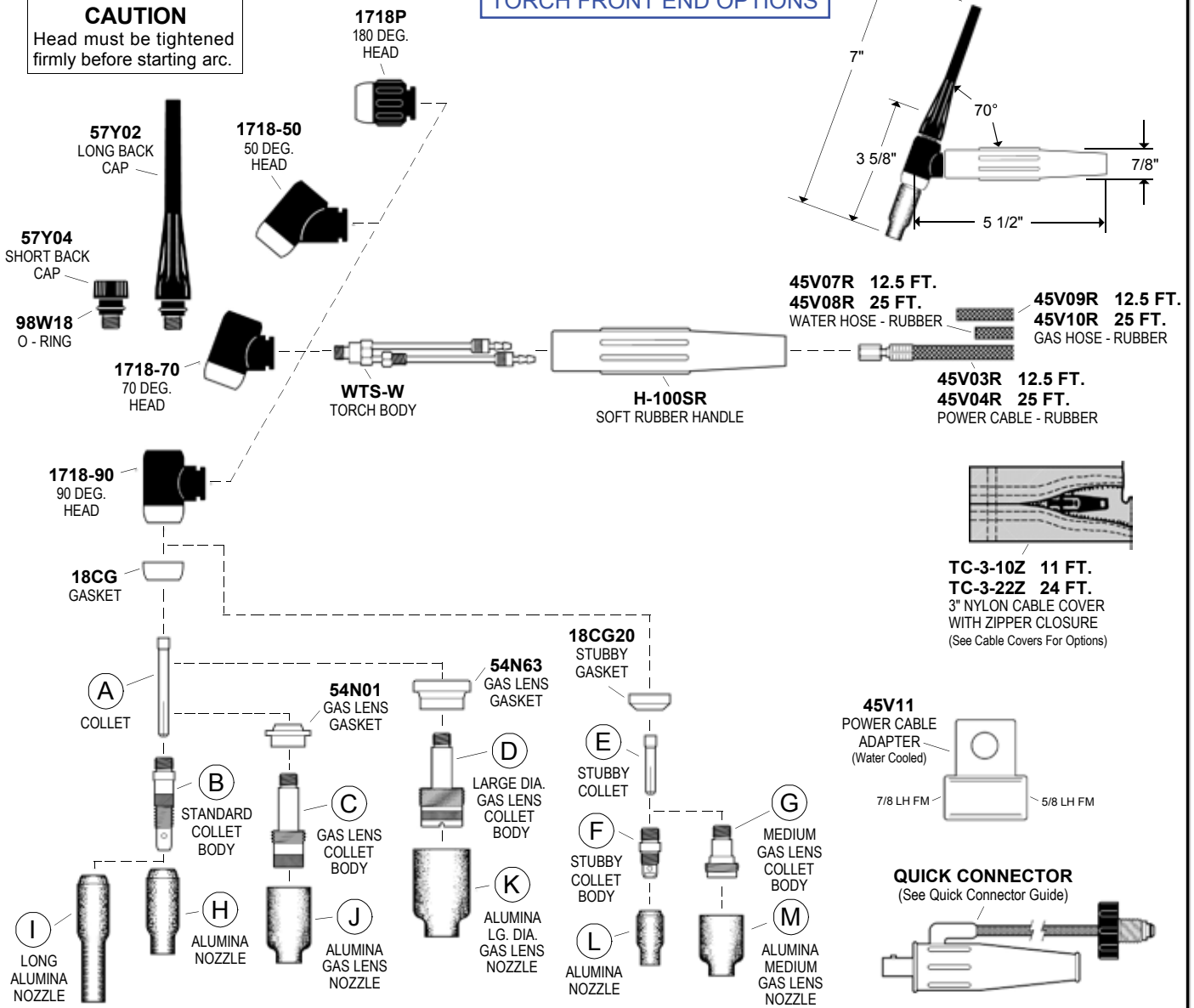
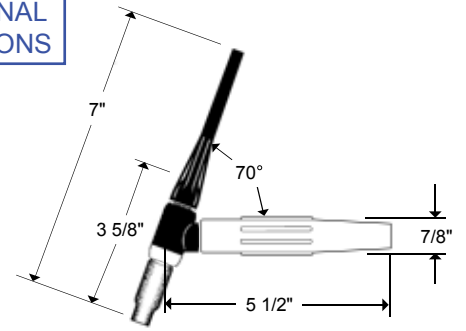

COPYRIGHT 2019 TEC WELDING PRODUCTS, INC.

COLLETS • COLLET BODIES • GAS LENS

ITEM	ELECTRODE DIAMETER	.020 0,5	.040 1,0	1/16 1,6	3/32 2,4	1/8 3,2
A	COLLET	10N21	10N22	10N23	10N24	10N25
B	STANDARD COLLET BODY	10N29	10N30	10N31	10N32	10N28
C	GAS LENS	45V29	45V24	45V25	45V26	45V27
D	LG. DIA GAS LENS	—	—	45V116	45V64	995795
E	STUBBY COLLET	—	—	10N23S	10N24S	10N25S
F	STUBBY COLLET BODY	17CB20				
G	STUBBY GAS LENS	—	—	45V25S	45V26S	45V27S

GAS NOZZLES

ITEM	NO. SIZE	4 1/4"	5 5/16"	6 3/8"	7 7/16"	8 1/2"	10 5/8"	11 11/16"	12 3/4"
H	ALUMINA	10N50	10N49	10N48	10N47	10N46	10N45	—	10N44
I	ALUMINA 3" LONG	—	10N49L	10N48L	10N47L	—	—	—	—
J	ALUMINA GAS LENS	54N18	54N17	54N16	54N15	54N14	—	54N19	—
K	ALUMINA LG. DIA. GAS LENS	—	—	57N75	—	57N74	53N88	—	53N87*
L	ALUMINA	13N08	13N09	13N10	13N11	13N12	13N13	—	—
M	ALUMINA STUBBY GAS LENS	—	—	—	54N15SW	54N14SW	54N12SW	54N19	—

* #15 53N89 15/16" ID X 1 7/8" Long

Specifications and descriptions subject to change without notice.

MANUFACTURED IN USA

TEC WELDING PRODUCTS, INC. • PO BOX 1870 • SAN MARCOS, CA 92079 • (760) 747-3700

www.tectorch.com

e-mail info@tectorch.com

www.weldtec.com

REVISION C